

Nov. 13, 1962

J. G. REAVIS ET AL

3,063,829

METHOD FOR OBTAINING PLUTONIUM METAL AND ALLOYS OF
PLUTONIUM FROM PLUTONIUM TRICHLORIDE

Filed April 8, 1960

3 Sheets-Sheet 1

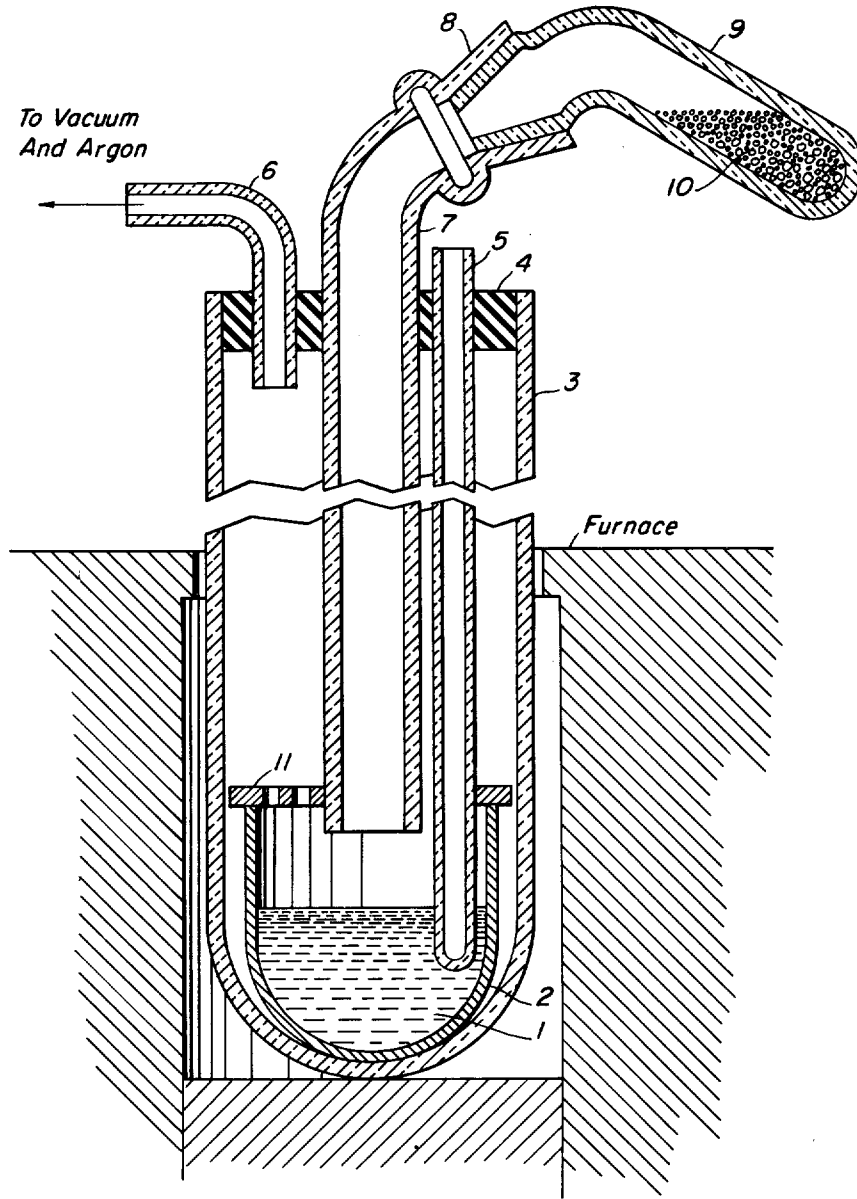

Fig. 1

WITNESSES:

Roy V. Smith, Jr.
Victor L. Lesko.

INVENTORS

James G. Reavis, Joseph A. Leary,
William J. Maraman

BY

Richard L. Anderson
Attorney

Nov. 13, 1962

J. G. REAVIS ET AL
METHOD FOR OBTAINING PLUTONIUM METAL AND ALLOYS OF
PLUTONIUM FROM PLUTONIUM TRICHLORIDE

3,063,829

Filed April 8, 1960

3 Sheets-Sheet 2

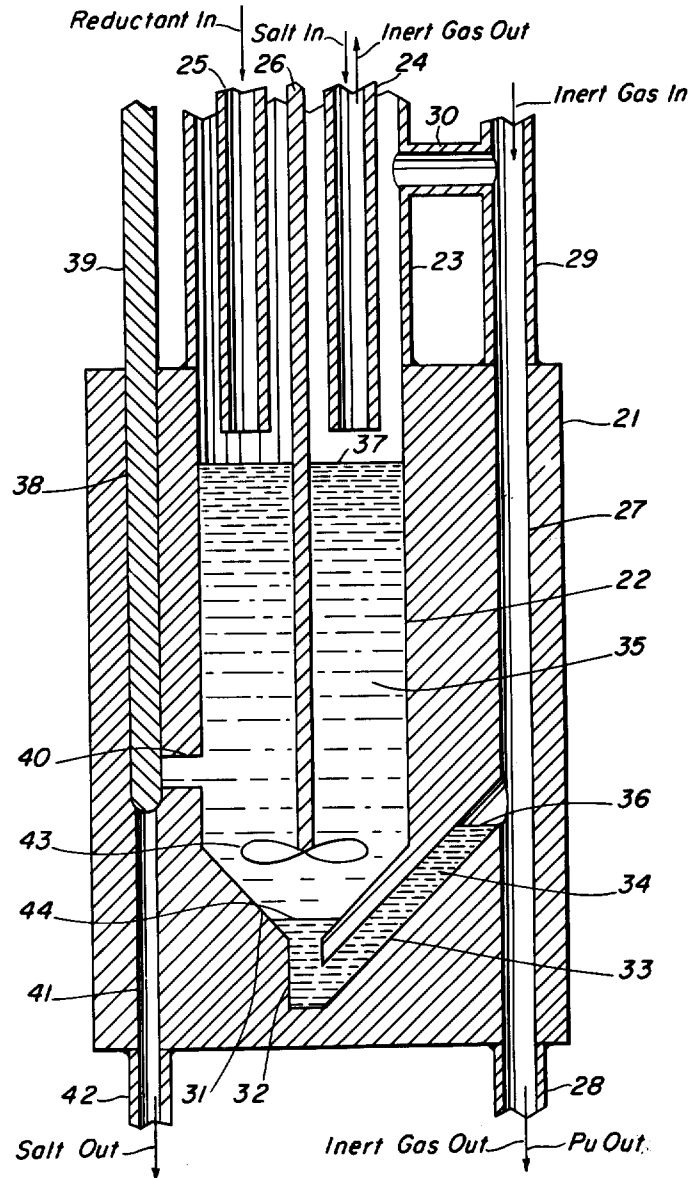

Fig. 2

WITNESSES:

Roy H. Smith, Jr.
Victor L. Leabo.

INVENTORS
James G. Reavis, Joseph A. Leary,
William J. Maraman
BY

Richard A. Goodson
Attorney

Nov. 13, 1962

J. G. REAVIS ET AL
METHOD FOR OBTAINING PLUTONIUM METAL AND ALLOYS OF
PLUTONIUM FROM PLUTONIUM TRICHLORIDE

3,063,829

Filed April 8, 1960

3 Sheets-Sheet 3

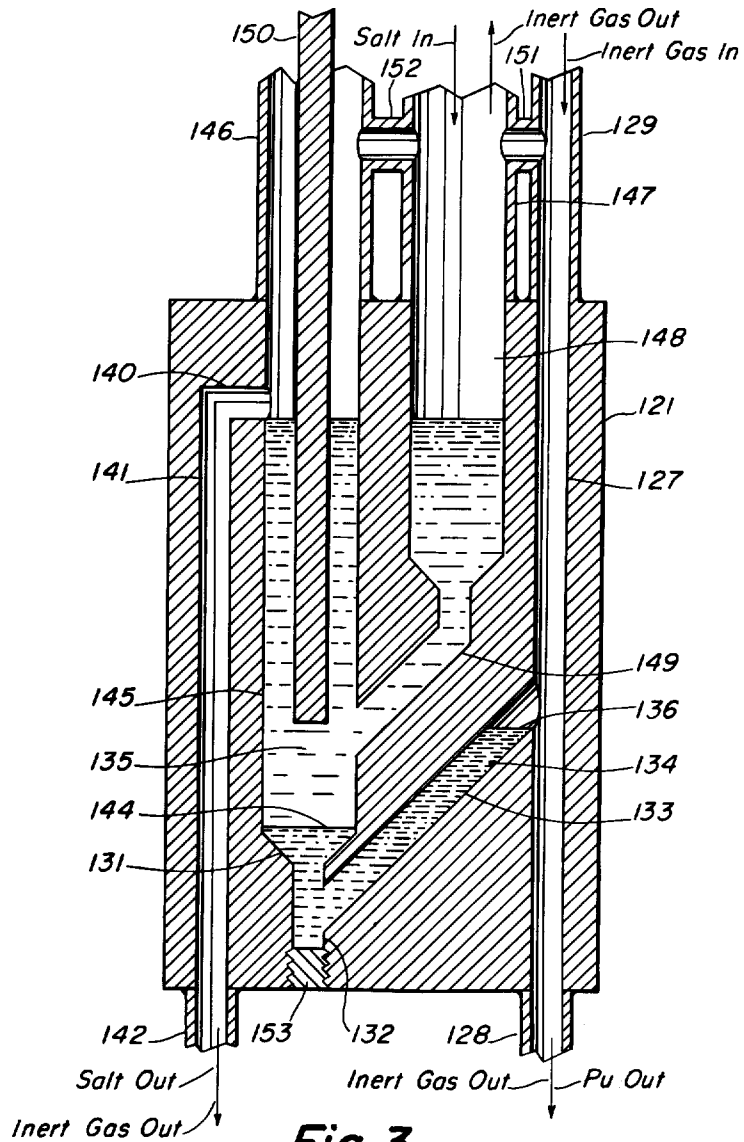

Fig. 3

WITNESSES:

Roy H. Smith, Jr.
Victor L. Lesko.

INVENTORS

James G. Reavis, Joseph A. Leary,
William J. Maraman

BY

Orlando A. Anderson
Attorney

1

3,063,829

METHOD FOR OBTAINING PLUTONIUM METAL AND ALLOYS OF PLUTONIUM FROM PLUTONIUM TRICHLORIDE**James G. Reavis, Joseph A. Leary, and William J. Maraman, Los Alamos, N. Mex., assignors to the United States of America as represented by the United States Atomic Energy Commission**

Filed Apr. 8, 1960, Ser. No. 21,073

5 Claims. (Cl. 75-84.1)

The present invention relates to methods for obtaining plutonium metal and plutonium alloys by the direct reduction of plutonium halides, and is more particularly concerned with such methods wherein a reducing metal which forms a chloride having a more negative standard free energy of formation than that of plutonium trichloride is used to reduce such plutonium trichloride. It is also within the scope of the present invention to perform such reductions with a reducing metal which does not appreciably reduce certain contaminating halides which may be present.

The present application is an undiminished continuation-in-part of application Serial No. 820,836, filed June 16, 1959, entitled "Method For Obtaining Plutonium Metal From Its Trichloride." The new material added hereinbelow is that relating to cerium reductions of PuCl_3 to obtain plutonium-cerium alloys and, when cobalt is added, to obtain Pu-Ce-Co ternary alloys. The properties of such alloys which make them useful as reactor fuels are disclosed in the patents issued to Coffinberry, U.S. Pat. 2,867,530 and 2,901,345.

The standard prior art method for obtaining plutonium by a reduction of its halides consists in the calcium reduction of plutonium tetrafluoride in the presence of iodine, U.S. Pat. 2,890,110. Advantage is taken of the exothermic reaction between iodine and calcium to limit the heat required from external heat sources to that required to initiate the calcium reduction of the fluoride, the reactions thereafter being self-sustaining, and an excess of calcium over that required for both the reduction of the PuF_4 and the iodide formation is used to push the reactions in the desired direction and thereby increase the yield. The exothermic heat of both reactions is also useful in keeping the plutonium and the slag in a molten condition for their ready separation.

The Baker process has come to be known as the "bomb" process because the reactions are necessarily conducted inside a heavy sealed metal container. The container must be evacuated, filled with argon and sealed after charging at room temperature to prevent oxidation of the reactants. The argon also reduces the extent to which the iodine penetrates the pores of the refractory liner inside the metal container. The container must have a heavy wall because high internal pressures are developed during the process, even before the other reactants combine with iodine. At 260° C., for example, probably all the iodine has been volatilized to create a partial pressure of about 6 atmospheres. As the temperature inside the container increases, further pressure increases are brought about by simple heating of both the iodine vapor and the argon. The free volume inside the container must be kept to a minimum to confine the iodine to the reaction zone, and thus the high pressures cannot be avoided by increasing the volume of the container.

Thus the only practicable bomb process is that in which the solid dry reactants are charged into the bomb at room temperature with a small free volume in the space above the charge. The bomb is sealed with a gasketed and bolted cover plate, the air in the free volume is replaced with argon, and the charge is heated by an

2

induction coil. After a few minutes, the temperature inside the reaction vessel begins to rise rapidly, induction heating is discontinued and the reaction is allowed to proceed at its own pace. After a rapid rise to a maximum temperature somewhere in the range of 1000 to 1600° C., the contents of the vessel are allowed to cool to room temperature. The bomb is opened to yield a solid plutonium button at the bottom and a solidified $\text{CaF}_2\text{-CaI}_2$ slag at the top.

The principal disadvantages of the bomb process as outlined above are that (1) it requires the use of iodine and extra calcium; (2) it is essentially a high pressure process and requires a thick-walled reaction vessel and (3) it is not amenable to continuous or semi-continuous operation, but is strictly a batch type operation. It is an object of the present invention to provide a process for obtaining plutonium metal through the reduction of plutonium halides which does not have such disadvantages.

Another object of the present invention is to provide methods and means for obtaining pure plutonium metal in high yield by reduction of the halides of plutonium without the use of booster reactants to provide a concurrent heat liberating reaction.

A further object is to provide such methods and means for obtaining plutonium metal wherein the pressure in the reaction vessel is never appreciably greater than that of the surrounding atmosphere.

An additional object is to provide such methods and means in which the reaction will contain the resulting reaction products in the molten solid states but has walls of a thickness not necessarily greater than that required for reactions at atmospheric pressure.

Another and further object is to provide such methods and means in which the products may be withdrawn continuously or semi-continuously, i.e., complete shutdown is not required except momentarily and/or after a long period of operation.

An additional object is to provide such methods and means wherein substantially pure plutonium metal is obtained from a plutonium halide contaminated with like halides of fission product elements, the bulk of the latter halides appearing in the slag.

Yet another object is to provide a process for both reducing the plutonium in a molten halide thereof to the metallic state and simultaneously alloying such plutonium with a reductant or with both such reductant and a third metal, which does not enter into the reaction, both types of alloys being useful as reactor fuels.

Still another object is to provide a method such as the foregoing which does not require the use of booster reactants, wherein the pressure in the reaction vessel is never appreciably greater than atmospheric and does not require a thick walled vessel, and the plutonium is separated during the process from fission products, the bulk of such contaminants appearing in the slag rather than the alloy.

The above and other objects are attained in the present invention by the direct reduction of plutonium trichloride (PuCl_3) with any one of several metals in a heated container filled with an inert gas, which may be initially at a pressure somewhat less than atmospheric but in no instance need be more than approximately atmospheric. The salt is melted under such pressure, after which the inert gas pressure is increased, if necessary, to about an atmosphere. The reductant is then added gradually, and the temperature is increased while maintaining the inert gas pressure at about an atmosphere. In the case of forming the Pu-Ce-Co alloys, the Ce-Co alloys are added in the form of sizeable chunks, e.g., of 1/2-in. dimensions, at the outset, and are allowed to react with the salt throughout all of the heating. This is the only practicable method of adding the reductant alloys used, as they have

lower melting points than the starting salts used, and they are too easily oxidized for ready handling in the form of granules. Fortunately, such alloys (and also cerium alone) do not react with the plutonium halides with the explosive violence of calcium, and there is no need for extreme caution in combining the reactants.

A non-reacting halide such as NaCl may be added with the PuCl_3 to serve as a flux, i.e., to reduce the melting point of the resulting salt slag below its undiluted value of 772°C . (CaCl_2) or 870°C . (LaCl_3) or 810°C . (CeCl_3). An alternate method of avoiding high pressures without volatilization or air leakage into the reaction vessel is to maintain the inert gas at a pressure slightly greater than that of the surrounding atmosphere and to allow gas to leak from the vessel at a rate sufficient to prevent any appreciable increase in pressure. This method was used in the cerium and cerium-cobalt reductions to be described below.

The method of the present invention can be more easily understood by referring to the attached drawings, of which:

FIGURE 1 illustrates apparatus suitable for conducting the processes of the present invention in a batchwise fashion, and was used with slight modifications in the work summarized in the examples below,

FIGURE 2 shows an apparatus suitable for carrying on the same processes semi-continuously, and

FIGURE 3 depicts apparatus in which some of the same processes may be carried on continuously.

Turning now to FIGURE 1, the general procedure is to charge the chloride or chlorides **1** in powder form into a suitable crucible **2**. The crucible **2** is placed inside a furnace tube **3**, which may be of a wall thickness no greater than that needed to withstand a vacuum and may, e.g., be of quartz for ready observation. The furnace tube **3** is sealed with a stopper **4** fitted with a thermocouple well **5**, a tube **6** for connection to a vacuum pump and an argon supply system, and a tube **7** for the addition of calcium or other granular reductant, the thermocouple well **5** and reductant tube **7** extending down into the crucible. The reductant tube may be conveniently terminated on the outside in a ground glass joint **8** slanted from the vertical as shown, the other member of such joint being connected to an otherwise closed container **9** filled with granular reductant **10** and having the bent section indicated. By pivoting container **9** about joint **8**, reductant **10** may be added at the will of the operator without affecting the atmosphere within the furnace tube. The crucible **2** is fitted with a tantalum lid **11** having appropriate openings for the reductant tube **7** and thermocouple well **5**, and a number of smaller vapor openings as well. The purpose of lid **11** is to reduce losses of reactants and products from crucible **2** by spattering and volatilization.

With all of the above components installed as indicated, the furnace tube is evacuated of air, and heat is supplied to raise the temperature of the crucible contents rather slowly while evacuation is continued. This is done to remove moisture and occluded gases from the reactants and the reaction vessel. When such temperature is between 200°C . and 450°C ., argon is admitted to a pressure of about half an atmosphere to prevent volatilization or spattering of the salt in the crucible. This pressure is somewhat arbitrary and was selected to insure a tight connection at ground glass joint **8** (with atmospheric pressure outside) and also to insure against a too rapid increase in pressure within the reaction vessel during heating. With gas tight seals at all openings and a relief valve in gas line **6**, such precautions are unnecessary, and a pressure of about an atmosphere may be used throughout all heating. This was the technique used in the cerium and cerium-cobalt reductions described below. In using the FIGURE 1 embodiment as shown, when the desired reduction temperature is reached, as indicated in more detail below, and before any reductant is added, the argon

pressure is adjusted to a few centimeters of mercury below atmospheric. This pressure increase reduces the stress on the tube **3** by the atmospheric pressure on the outside, insures against air leakage into the tube, and prevents further spattering in the crucible as local high temperatures or "hot spots" may develop in the reactants and products.

In some cases, specifically, the lanthanum and cerium reductions described below, the apparatus pictured in FIG. 1 was modified to permit introduction of the reductant as a solid rod. This is desirable because it permits the use of pyrophoric and easily oxidizable material in a more convenient form, and also because it permits withdrawal of the unused portion of the reductant rod when the reduction is completed, at least for those reductants which do not alloy with plutonium. As noted below in connection with Example 11, it is not particularly desirable for the second purpose with cerium, as the excess rod absorbs plutonium. The reductant introduction tube was replaced by a molybdenum rod of small diameter which was used to suspend the rod of reductant. The temperature and pressure of the system were adjusted as outlined in preceding paragraphs before addition of the reductant. The bar of reductant was then lowered by pushing down the molybdenum rod to immerse the end of the reductant bar in the PuCl_3 -containing salt. As the end of the bar was used up in the reaction, the bar was lowered further to add more reductant to the system. After an appropriate reaction time the reductant was withdrawn from the salt, in the case of lanthanum, and the system was cooled. The cerium reductions demonstrated that the withdrawal of excess cerium is impractical.

The apparatus of FIGURE 1 defines a large gas volume above the reaction crucible, this volume extending, in the particular apparatus used, about 11 inches above the 4-inch high crucible in the 2-inch I.D. furnace tube. The large volume of gas acts as a cushion for the expansion of locally heated gas, i.e., the gas contacting the reactants and products. When the apparatus was used in the reductions of the examples below, no significant pressure increase occurred after the adjustment described above, i.e., the total pressure remained at about atmospheric during the reductant addition and thereafter. This large gas volume also served the practical purpose of insulating stopper **4** from the high temperature of the reaction zone. With a refractory type closure and the appropriate relief valve mentioned above, such volume can be reduced considerably.

Using the above described apparatus and generally described method, two attempts were made to reduce PuCl_3 in a PuCl_3 -NaCl mixture by gradual addition of small pieces of Mg to the molten salt mixture in a quartz crucible. In both cases the yield of Pu metal was too low to be acceptable (less than 50%).

A number of calcium reductions were made using both pure PuCl_3 and PuCl_3 -NaCl mixtures, and using each type of salt in both tantalum crucibles and in ceramic crucibles composed of 10 percent by weight (w/o) of TiO_2 , balance MgO. In each case, 25 percent molar excess of granular Ca was used as the reductant. Also in each case, the plutonium chloride was prepared from plutonium metal of about 99.9 percent purity. Four reductions of PuCl_3 from PuCl_3 -NaCl mixtures were made by dipping lanthanum rods into the molten salt contained in MgO-10 w/o TiO_2 crucibles, the total amount of La present in each reduction being in large excess of the amount needed for complete reduction of the PuCl_3 . After the reaction had proceeded for the desired length of time, the excess La was withdrawn to break contact with the salt.

A number of reductions of PuCl_3 were accomplished by dipping cerium rods into molten salt contained in MgO-10 w/o TiO_2 crucibles, the amounts of the reactants

5

varying as indicated in the specific examples below. The quartz furnace tube was evacuated after introduction of the reactants and while heating to above 100° C. but not above 450° C., after which the tube was filled to and maintained at atmospheric pressure with argon during the balance of the run. Conditions were the same for the cerium-cobalt reductions exemplified below except that the Ce-Co was added to the salt at the outset as massive pieces, as already noted. After completion of the heating cycle in each run, the cooled crucible was broken to yield a well formed massive metal button well separated from the solidified halide slag. The buttons were cleaned and analyzed for Pu, Ce, La and Co, as noted in each case.

Specific examples of the above methods and results follows:

(1) *Ca Reduction, Tantalum Crucible, Undiluted PuCl₃*

After reaching a steady temperature of 773° C. as indicated by a thermocouple junction at the bottom of the well, the calcium was added at the rate of 0.5 to 1.0 gram per minute. The maximum temperature observed during the Ca addition was 850° C. because of the exothermic nature of the reaction. At the end of such addition, the temperature of the reaction products was 803° C. Heating was discontinued and the contents of the crucible were allowed to cool to room temperature. The bulk of the slag was removed mechanically, and the balance by leaching with dilute HNO₃.

The plutonium metal in the crucible presented a smooth, dense surface, and was removed by dissolution in dilute HCl. The metal contained about 0.1 weight percent Ca, 0.02 weight percent Ta, and the balance essentially plutonium (98.5 w/o). The yield from a starting weight of plutonium in the chloride of 25.02 grams was 99.9 percent. The slag contained 0.06 weight percent PuCl₃ and accounted for 0.03 percent of the starting weight of plutonium.

(2) *Ca Reduction, MgO-TiO₂ Crucible, Undiluted PuCl₃*

The first calcium was added to a quantity of fused PuCl₃ containing 16.65 grams of plutonium in the crucible after the argon pressure had been adjusted to a few centimeters less than atmospheric at a steady temperature of 757° C. The calcium addition was continued at the rate of 0.5–1.0 gram per minute until the 25 percent molar excess had been added, during which time the temperature in the crucible rose to 785° C. Since previous reductions had indicated the necessity for a further increase in temperature to obtain a smooth, mechanically separable Pu regulus when using the oxide crucible, the furnace heating rate was increased to raise the crucible temperature to 850° C. At this point the furnace was shut off, and the tube and contents were allowed to cool to room temperature.

The ceramic crucible was broken open, and the metal button and solidified slag were mechanically separated. The plutonium was leached with dilute HNO₃ to remove adhering slag and calcium, after which it was dried, weighed, and dissolved in dilute HCl for analysis. The separated slag was similarly weighed and dissolved in dilute HNO₃ for analysis.

The results of the analyses indicated a 95 percent plutonium yield, with 4 weight percent of the slag consisting of PuCl₃ and accounting for 2 percent of the starting plutonium (the balance presumably appearing in the crucible). The plutonium button was found to contain less than 0.03 weight percent Ca, the balance being essentially all Pu, i.e. Pu > 99.0 weight percent.

(3) *Ca Reduction, Ceramic Crucible, 80 w/o PuCl₃-20 w/o NaCl Salt*

The mixed salts contained 9.35 grams of plutonium. Calcium addition was commenced at 575° C. and continued through a crucible temperature rise to 590° C. at

6

the rate of 0.5–1.0 gram per minute. The heating rate was increased until the crucible temperature rose to 850° C., after which the furnace was shut off and the tube and contents were cooled to room temperature.

The products were separated for analysis as in Example 2, again yielding a dense plutonium button. The analyses indicated a plutonium yield of 98.5 percent, with the slag consisting of 0.07 weight percent PuCl₃ and accounting for 0.5 percent of the starting plutonium. The metal button contained 0.02 weight percent Mg, 0.01 weight percent Ca, 0.10 weight percent Ti, balance essentially pure plutonium (>99.0 weight percent).

(4) *Ca Reduction, Ta Crucible, 80 w/o PuCl₃-20 w/o NaCl Salt*

The mixed salts contained 13.43 grams of plutonium. Calcium was added at the rate of 0.5–1.0 gram per minute in the range of 700–715° C. It was found that a dense pool of molten plutonium forms at 715° C. and that heating to a higher temperature is unnecessary. The furnace was shut down at 715° C. and the products cooled to room temperature.

The crucible contents were removed as in Example 1, disclosing a smooth, dense plutonium button. The metal and slag were weighed and analyzed to indicate a plutonium yield of 98.5 weight percent, with 0.05 percent of the starting plutonium appearing in the slag. The metal contained about 0.10 weight percent Ca and 0.02 weight percent Ta, balance essentially pure plutonium (>99.0 weight percent).

(5) *Ca Reduction, Ceramic Crucible-Contaminated Salt*

The same type of MgO-10 weight percent TiO₂ crucible as in Example 3 was used, but the salt mixture contained 5 weight percent mixed rare earth chlorides, 19 weight percent NaCl and 76 weight percent PuCl₃. Following the same procedure of adding calcium slowly when the argon pressure is slightly less than atmospheric, the addition was started at 520° C. and continued to 565° C. The crucible temperature was raised to 860° C., after which the furnace was shut down and the tube allowed to cool to room temperature.

Upon separating and analyzing the products in the usual manner, it was found that the plutonium yield was 99 percent, the PuCl₃ concentration in the slag being 0.4 weight percent and accounting for 0.45 percent of the starting plutonium. However, the plutonium button analysis revealed that virtually all of the rare chlorides had been co-reduced with the PuCl₃, and accounted for an appreciable fraction of the weight of the button.

The work summarized in the above examples was also repeated with decreasing molar excesses of calcium. This further work indicated that a 15 percent molar excess of calcium is required to insure a plutonium yield exceeding 90 percent, and that at least a 20 percent calcium excess is necessary to obtain the high plutonium yields of the examples, i.e., 95 to 99.9 percent.

(6) *La Reduction, Ceramic Crucible, PuCl₃-NaCl Salt*

The lanthanum reductant was added to a fused salt melt consisting of 79 weight percent PuCl₃ and 21 weight percent NaCl after the latter had been raised to a temperature of 700° C. and the argon pressure above the crucible had reached atmospheric pressure. The lanthanum was in the form of a rod of 0.5 cm.² cross sectional area, the addition being accomplished by lowering the La rod into the melt from a 1/8-inch diameter molybdenum suspension rod passing through the stopper of the furnace tube. As the end of the La rod was consumed during the reaction, the balance of the rod was lowered to add fresh reductant to the melt. The amount of La thus contacted was in large excess of the stoichiometric amount for the complete reduction of the PuCl₃.

After 25 minutes at 700° C., during which not more than 10° C. rise because of exothermic reaction was ob-

served, the La rod was withdrawn and heating was discontinued. The cooled crucible was broken open to reveal a well formed plutonium button. Upon separation of the metal from the slag and subsequent analysis, it appeared that the yield of Pu was 91 percent from a starting weight of 13.64 grams in the trichloride. The concentration of La in the metal was less than 0.007 weight percent, and the concentration of PuCl_3 in the slag was 7.0 weight percent.

(7) *La Reduction, Ceramic Crucible, PuCl_3 -NaCl Salt*

Example 6 was repeated, the only difference being that the composition of the salt phase was 80 weight percent PuCl_3 -20 weight percent NaCl, the weight of the combined Pu being 20.07 grams.

In this instance the yield of plutonium in a well formed button was 90 percent, the concentration of the lanthanum therein being 0.27 weight percent. The concentration of the PuCl_3 in the slag was 6.0 weight percent.

(8) *La Reduction, Ceramic Crucible, PuCl_3 -NaCl- CeCl_3 Salt*

The procedure of Example 6 was again followed except that the reaction was continued for 35 minutes at 700°C . and 1 atmosphere of argon. The salt composition was 77 weight percent PuCl_3 , 19.5 weight percent NaCl and 3.5 weight percent CeCl_3 , with 15.26 grams Pu and 0.56 gram Ce in the chlorides.

Again a well formed massive metal was obtained, assaying 0.09 weight percent La and 0.38 weight percent Ce. The plutonium yield was 94 percent, and the concentration of PuCl_3 in the slag was 1.5 weight percent.

(9) *La Reduction, Ceramic Crucible, PuCl_3 -NaCl- CeCl_3 Salt*

Example 8 was repeated with a salt melt of composition 78 weight percent PuCl_3 -19.7 weight percent NaCl-2.3 weight percent CeCl_3 containing 17.37 grams Pu and 0.41 gram Ce in the chlorides. The Pu yield was 95 percent, and the metal was found to contain 0.17 weight percent La and 0.09 weight percent Ce. The concentration of PuCl_3 in the slag was 1.4 weight percent.

(10) *Ce Reduction and Pu-Ce Alloy Formation*

A cerium rod, approximately three inches long and weighing about 13 grams, was slowly added to 24.137 grams of a salt melt consisting of about 78 w/o PuCl_3 , 19.5 w/o NaCl and 2.5 w/o LaCl_3 blanketed by argon at prevailing atmospheric pressure. The addition was made over a 20 minute period while the temperature was held in the range 688 - 698°C . This temperature was held for an additional 10 minutes and the system was then cooled. Analysis of the metal button which was produced showed that 93% of the starting weight of the plutonium appeared in the alloy, which consisted of 73 w/o Pu, 27 w/o Ce and less than 0.06 w/o La. The La/Pu weight ratio had changed from 0.029 in the original salt to less than 0.0008 in the product alloy, giving a lanthanum decontamination factor greater than 35, i.e., the ratio of lanthanum to plutonium in the original salt divided by the ratio of lanthanum to plutonium in the product was greater than 35.

(11) A cerium rod weighing 18.49 grams was slowly added to 34.863 grams of molten 76.2 w/o PuCl_3 , 19.7 w/o NaCl, 4.1 w/o LaCl_3 over a 20 minute period at 660 - 685°C . A small fraction of the cerium bar was retrieved at the end of this period while the salt and alloy remaining the crucible were maintained in this temperature range an additional 10 minutes before cooling. The metal button was found to contain 91% of the total plutonium in the system as an alloy of 84 w/o Pu, 16 w/o Ce and 0.07 w/o La, indicating a lanthanum decontamination factor of 50. The cerium bar which had been withdrawn contained 7.0% of the total plutonium in the system in an alloy consisting of 35 w/o Pu and 65 w/o Ce. The alloy formed in the cerium rod appeared to be

homogeneous, the plutonium having migrated above the level of the molten salts. While this might prove to be a useful technique for forming Pu-Ce alloys of high cerium content, it is not considered particularly desirable to form two Pu-Ce alloys of different compositions in the process of the present invention. This example indicates the necessity for determining the amount of cerium in advance of operation, and actually adding all of the cerium thus determined.

(12) A cerium rod weighing 13.265 grams was added to 35.447 grams of the same salt mixture as was used in Example 11. The addition was made over a 10 minute period at a temperature of 650 - 656°C . and the system was cooled immediately. The metal button contained 88% of the total plutonium in an alloy of 86 w/o Pu, 14 w/o Ce and 0.03 w/o La. This composition indicates a lanthanum decontamination factor of about 116.

(13) A cerium rod weighing 9.225 grams was added to 30.154 grams of fused salt consisting of 75.3 w/o PuCl_3 , 19.3 w/o NaCl, 2.7 w/o CeCl_3 and 2.7 w/o LaCl_3 over a period of 5 minutes at 693 - 703°C . After the rod had all been added the reduction products were held at this temperature for an additional 10 minutes before cooling. Analysis of the metal button showed 90% of the total plutonium was present in an alloy of 98.9 w/o Pu, 1.1 w/o Ce and less than 0.004 w/o La. The indicated lanthanum decontamination factor was greater than 750. In this case the cerium added to the salt was 100.3% of the stoichiometric amount for a complete reduction, and the results indicate the minimum cerium content of the plutonium alloy formed by such reductions to be 1.1 w/o (1.86 a/o).

(14) 10.109 grams of cerium was added to 31.180 grams of fused salt containing 75.2 w/o PuCl_3 , 19.9 w/o NaCl, 2.2 w/o CeCl_3 and 2.7 w/o LaCl_3 over a 10 minute period at a temperature of 690 - 710°C . The reduction products were immediately cooled at a rate of $2^\circ\text{C}/\text{min}$. The metal button contained 90% of the total plutonium in an alloy of 97.4 w/o Pu, 2.6 w/o and less than 0.1 w/o La. The lanthanum decontamination factor was greater than 24.

Ce Reduction and Pu-Ce-Co Alloy Formation

In Examples 15-18 below, the reductant alloy was 5.5 w/o Co, 94.5 w/o Ce (12 a/o Co, 88 a/o Ce), and the salt composition was 75.2 w/o PuCl_3 , 19.9 w/o NaCl, 2.2 w/o CeCl_3 , and 2.7 w/o LaCl_3 , the latter being used as a representative rare earth fission product contaminant. CeCl_3 was included in the salt simply because it was available from previous reductions with lanthanum; it is inert here and could have been omitted without effect. The chunks of metal were combined with the salt at room temperature, heated slowly to about 100°C . while evacuating, then more rapidly to the reduction temperature under streaming argon.

(15) 18.780 grams of Ce-Co alloy were combined with 13.140 grams of the salt and heated from about 100°C . to 775°C . at a rate of about $8^\circ\text{C}/\text{min}$. After holding at 775°C . for 4 minutes the system was cooled at about $8^\circ\text{C}/\text{min}$. Analysis of the metal button showed a plutonium yield of 98.4% in an alloy of about 32 w/o Pu, 64 w/o Ce, 5 w/o Co and less than 0.2 w/o La. (Button composition percentages do not add up to 100% because of analytical errors.) This corresponds approximately to an alloy of 20 a/o Pu, 12 a/o Co and 68 a/o Ce, which was the desired product. In the process the La/Pu weight ratio changed from 0.024 to less than 0.005 which indicates a lanthanum decontamination factor greater than 5. The actual lanthanum decontamination factor may have been much greater than this value since the analysis set only an upper limit on the possible lanthanum concentration in the ternary alloy. (Analyses for lanthanum in solutions of high cerium content are severely limited.)

(16) 17.246 grams of the Ce-Co alloy were combined

with 12.033 grams of the salt and the mixture was heated at a rate of about 10 deg./min. from 100° C. to 550° C. The system was held at about 550° C. for 40 minutes and cooled at about 6 deg./min. The ternary alloy produced contained about 97% of the plutonium in the system. The composition of the alloy was about 31.5 w/o Pu, 63.4 w/o Ce, 4.9 w/o Co and less than 0.2 w/o La. The indicated lanthanum decontamination factor is greater than 4.

(17) 18.411 grams of the Ce-Co alloy were combined with 12.568 grams of the salt and heated from about 100° C. to 635° C. at a rate of about 10 deg./min. The system was held in the temperature range 635–650° C. for 12 minutes and cooled at about 8 deg./min. The button contained about 93% of the plutonium and the composition was 31.4 w/o Pu, 64.1 w/o Ce, 5.1 w/o Co and less than 0.2 w/o La. The indicated lanthanum decontamination factor is greater than 4.

(18) 17.470 grams of Ce-Co alloy were combined with 31.058 grams of salt and heated from about 100° C. to 700° C. at a rate of about 15 deg./min. The system was held in the temperature range of 700–720° C. for 15 minutes and cooled at about 8 deg./min. About 93% of the total plutonium appeared in the button, which contained 66.6 w/o Pu, 29.9 w/o Ce, 4.3 w/o Co and less than 0.1 w/o La. The indicated lanthanum decontamination factor is greater than 12. The composition of this alloy was 49.3 a/o Pu, 37.8 a/o Ce and 12.9 a/o Co, which approximates the intended composition.

FIGURE 2 illustrates an apparatus suitable for practicing the present invention on a semi-continuous basis. This apparatus consists essentially of a number of tubes, preferably of tantalum or other non-reactive metal, disposed in registering and sealing relationship with a number of cylindrical cavities in a block 21 of non-reactive metal which does not alloy with plutonium, e.g., tantalum, the latter being disposed in a furnace or being provided with heaters inserted in appropriate cavities (not shown). Thus the reaction chamber 22 registers in sealing relationship with the tube 23, the latter extending above block 21 to provide a gas volume as in FIGURE 1 and fitted at the top with a closure (not shown) provided with appropriate passages for salt addition tube 24, metal addition tube 25, stirrer shaft 26 and any auxiliary devices used, e.g., a thermocouple well.

Through passage 27 in block 21 registers with plutonium outlet tube 28 at the bottom of the block and the inert gas inlet tube 29 at the top, the latter tube being connected to furnace tube 23 by one or more cross tubes 30. Reaction chamber 22 is tapered at its lower end 31 as shown and is connected through the small vertical cavity 32 and the diagonal riser cavity 33 to through cavity 27, this arrangement being generally known as an "overflow weir." By this arrangement liquid plutonium 34 can drain through the lower end of cavity 28 and out through tube 28, but the inert gas pressure at the maximum plutonium level 36 is always equal to that at the top of the melt 37, thereby preventing a siphoning action which could remove all of the liquid plutonium 34 and the melt 35 if no such arrangement were provided.

The stopper rod 39 operates slidably and sealingly in cavity 38 to block any possible flow from reaction chamber 22 through cavity 40 to the smaller bore salt drainage cavity 41 and salt drainage tube 42, as shown. Stirrer 43 is provided to agitate the melt and insure rapid contact between the PuCl₃ and the calcium, lanthanum or other metal reactant. This is highly desirable because freshly added reactants do not immediately form a uniform dispersion throughout the reaction zone. Calcium, for instance, will float on the surface 37 of melt 35, while freshly added PuCl₃ granules tend to sink in a melt of CaCl₂ or LaCl₃ and NaCl. Although the liquid forms of these salts, including any NaCl, are completely miscible at the operating temperature and eventually will form uniform solutions in which the PuCl₃ will be reduced to form Pu and CaCl₂ or LaCl₃, the reduction

will be considerably hastened by the agitating action of stirrer 43.

In a starting up operation, stopper rod 39 is placed in the closed position shown, the system is purged, and an inert gas such as argon or helium is admitted from the top of tube 29. It is preferable to maintain the inert gas pressure within the device at a slightly higher pressure than that on the outside, to insure against air or oxygen leaks into the apparatus. This is most easily accomplished by pumping purified argon in through tube 29 and permitting it to leak out through plutonium exit tube 28 and either or both the salt addition tube 24 and the reductant addition tube 25. The effluent gas may, of course, be collected and re-purified. Such a system may be made continuous by old and well known methods. The flowing gas contributes the further advantage of carrying off some of the exothermic heat and makes it possible to reduce the large gas volume mentioned above.

PuCl₃ (and NaCl) may then be added in powder form through tube 24, followed by heating and then gradual additions of calcium through tube 25, or the apparatus may first be heated to the reaction temperature and the salts and the reductant may be gradually added, simultaneously or separately. These additions may be accomplished through means not shown similar to the reductant addition tube 9 of FIGURE 1, the latter being modified to provide a passage for the exit of the argon.

Some amount of care must be exercised in determining the weight and volume of the initial charge to prevent the escape of unreacted PuCl₃ through tube 28, e.g., if only the salts are melted first, the charge must be calculated to keep the liquid level in the reaction chamber 22 no higher than the maximum plutonium level 36. When the initial charge has reacted and the dense liquid plutonium has collected in the diagonal riser 33 and vertical cavity 32, the plutonium level in 33 will fall below the level of the fused salts in reaction chamber 22, the difference in height depending on the relative densities of the two liquid phases in a well known and calculable manner.

Thereafter more of the reactant salt, with or without the NaCl diluent, and more of the metal reductant may be added. Either the salts may be added batchwise, followed by gradual additions of the metal, or both may be added gradually at about the same time. The latter is preferred because it brings the reactants into contact with one another more quickly than the batchwise additions. The stirrer 43 is activated to further promote a rapid reduction.

As the additions proceed and more products are formed, the level of the salt phase and the two levels of the plutonium phase rise until plutonium begins to drip over from diagonal riser 33 into cavity 27, through which it falls into outlet tube 28. As more raw materials are added and the reaction continues, the overflow and collection of such plutonium continues. Since the salt continues to accumulate as plutonium is being removed, level 37 continues to rise while the plutonium level in riser 33 remains fixed at its maximum 36, the result being a lowering of the salt-plutonium interface 44. By taking into account the densities of the two phases and the maximum safe plutonium accumulation consonant with non-criticality, the maximum salt height prior to drainage is readily determined.

When the salt has accumulated to a level 37 such as shown in FIGURE 2, and the reduction of the PuCl₃ is complete, stopper rod 39 is raised to permit the salt to discharge through cavities 40 and 41 and tube 42. The discharge of plutonium temporarily ceases, as the level in riser 33 adjusts to a value lower than the maximum 36. No plutonium metal can follow the outgoing salt, as the location of cavity 40 is higher than the maximum plutonium level 36, i.e., the intersection of riser 33 and cavity 27. There can be no pumping action to force

11

out any liquid below the lower wall defining cavity 40 because of the equal gas pressures above such liquid and above the plutonium in riser 33.

The above described salt drainage is, of course, accomplished very quickly. Immediately thereafter the stopper rod is lowered to the closing position, and the additions of raw materials are recommenced. Although the salt discharge is batchwise, the flow of plutonium, the product for which the structure was devised, is halted for only a few seconds out of every 15 minutes or so. Thus the apparatus of FIGURE 2 provides a means for obtaining substantially a continuous reduction of the plutonium halide to the metal.

FIGURE 3 illustrates an apparatus similar in most respects to the embodiment of FIGURE 2, analogous parts being designated by the same numerals prefixed by the digit "1" to form a 100 series. Thus the tantalum block 121, through cavity 127, plutonium exit tube 128, inert gas inlet tube 129, frusto-conical cavity 131, vertical cavity 132, diagonal riser 133, liquid plutonium 134, salt melt 135, maximum plutonium level 136, horizontal cavity 140, salt drainage cavity 141, salt drainage tube 142 and salt-plutonium interface 144 correspond to the parts of FIGURE 2 numbered in the sub-one hundred series, as above mentioned, and are similarly disposed. The major differences are that in FIGURE 3 a smaller bore reaction chamber 145 and correspondingly smaller co-axial and sealingly registering furnace tube 146 are provided, salt addition tube 147 is joined in sealing and registering relationship with a corresponding cavity 148 in tantalum block 121, such cavity 148 is connected to the lower part of reaction chamber 145 by passage 149 (not necessarily diagonal as shown), and the reducing metal is in the form of a rod 150 suspended in the salt melt 135 by a supporting structure at the top of furnace tube 146 (not shown). This structure may include suitable means for lowering rod 150 into the melt as it is consumed.

There is no stopper rod in the FIGURE 3 embodiment, but the horizontal salt drainage cavity 140 is disposed at a higher location in reaction chamber 145, and the vertical salt drainage cavity 141 is correspondingly longer than the corresponding elements of the FIGURE 2 embodiment. Cross tubes 151 and 152 permit the flow of the inert gas introduced through 129 into tubes 146 and 147 to equalize the pressures therein with the pressure exerted on the surface of the plutonium in riser 133. The long length of reducing metal rod 150 immersed in salt melt 135 insures adequate surface for the reduction reaction. Element 153 is a tantalum plug, removable for drainage purposes during shutdown.

While it is apparent that the FIGURE 3 embodiment may be operated in a manner similar to that of the FIGURE 2 apparatus, i.e., adding the salts as granules and melting them in the reaction chamber 145 and cavity 148, the preferred method of operation is by the introduction of the salt composition to be used as a liquid phase. Thus the liquid salt phase added through 147 is most conveniently the end product of the process disclosed in the patent issued to Reavis et al., U.S. Pat. 2,886,410. That patent discloses a process by which a partially spent plutonium fuel displaces the zinc in a chloride melt to form a melt of PuCl_3 and NaCl , at the same time stripping a number of fission products from the plutonium by preferential dissolution and distillation. Since that process may be carried on continuously and since one of the overall objectives of the present invention is the development of a continuous process for the purification (decontamination) of such plutonium fuels, the end product of that process is piped into the tube 147 as a liquid. Otherwise the operation of the FIGURE 3 embodiment is the same as the operation of the FIGURE 2 embodiment, except that the rate of rise of the salt phase in reaction chamber 145 must

12

be more carefully controlled to insure a maximum reduction of the PuCl_3 by the reductant rod 150.

In considering the minimum and optimum operating temperatures for the reductions exemplified above and illustrated as adaptable for semi-continuous and continuous operation with the apparatus embodiments of FIGURES 2 and 3, respectively, it is apparent that a number of factors must be considered. In each process the minimum temperature must exceed the melting point of plutonium (640°C.) or its alloys, in the cerium or cerium-cobalt reductions, to obtain a well consolidated metal product, and must also exceed the melting points of both the reactant salt and the product salt. These melting points, for the pure undiluted salts, are, in degrees Celsius:

PuCl_3 -----	770
CaCl_2 -----	772
LaCl_3 -----	870
CeCl_3 -----	810

When the PuCl_3 is diluted with NaCl , the melting points of the reactant salt and the product salt are reduced. Each of the four systems discussed has a simple eutectic type of phase diagram with no compound formation, the eutectic points being approximately:

Composition:	Temperatures, degrees C.
77 w/o PuCl_3 -23 w/o NaCl -----	453
66 w/o LaCl_3 -34 w/o NaCl -----	543
67 w/o CaCl_2 -33 w/o NaCl -----	505
74 w/o CeCl_3 -26 w/o NaCl -----	500

(Pure NaCl melts at about 800°C.)

In considering the alloys of plutonium formed by reductions with cerium or cerium plus a cobalt diluent, reference to the above mentioned Coffinberry patents indicates that the Pu-Ce alloys have a melting point below 700°C. for a plutonium content ranging from 63 w/o to 100 w/o (50-100 a/o), with a minimum melting point of about 600°C. at 95 a/o plutonium. (See U.S. Pat. 2,867,530.) The ternary alloys have melting points below 500°C. for cobalt in the range 10-20 a/o, plutonium in any content up to 88 a/o, balance cerium as indicated in U.S. Pat. 2,901,345.

Another factor to be considered is the material of the reaction crucible for the particular reaction. As indicated in Examples 2, 3 and 5, it was necessary to raise the reaction temperature to about 825 - 850°C. , in making calcium reductions in a ceramic crucible to obtain a well formed reduction button. No explanation for such required temperature increase is apparent, and no necessity therefor appeared in the calcium reductions in a tantalum crucible or in the lanthanum reductions in a ceramic crucible. With the former, massive metal was produced at about 800°C. from undiluted PuCl_3 and at 700 - 715°C. from the mixed salts of approximately eutectic composition (20 w/o NaCl). The lanthanum reductions of salts of the same composition also yielded good metal at about 700°C. No La reductions of undiluted PuCl_3 were made because it was desired to keep the reductant rod in the solid phase.

All of the PuCl_3 reductions by cerium were carried on in ceramic (MgO -10 w/o TiO_2) crucibles and resulted in well formed alloy buttons, ranging in cerium content from 1.1. to 27 w/o, with reaction temperatures in the range of from 650 to 710°C. The reductions of PuCl_3 by Ce-Co alloys were made in ceramic crucibles of the same composition and also yielded well formed massive metal at reaction temperatures in the range 550 - 775°C.

When the apparatus of FIGURE 3 is used for a continuous reduction process, it is desirable that the reductant rod remain in the solid phase. To insure such condition, the fused salts should be maintained at a temperature below the melting point of calcium (about 850°C.), lanthanum (about 825°C.), or cerium (810°

C.); whichever is employed. For a batch process or for semi-continuous operation, the operating temperature may be high enough to permit melting of the reductant.

In considering optimum temperatures and time, it is apparent that little would be gained by increasing the reaction temperature for the calcium reductions above those indicated supra because the yields and the quality of the reduced metal are quite satisfactory. The time at reaction temperature poses no problem, as the attainment of a steady temperature after completion of a rapid exothermic excursion indicates completion of the reaction. With lanthanum and cerium reductions, no readily apparent exotherm occurs, and a comparison of Examples 6 and 7 with 8 and 9 indicates an increase in yield with an increase in reaction time. It is also possible that the yield may be increased by raising the temperature of the reaction.

Examples 8 and 9 demonstrate a significant decrease in the cerium to plutonium ratio in the lanthanum reductions. Thermodynamic calculations indicate that lanthanum will likewise reduce PuCl_3 much more readily than the chlorides of the other rare earths. Thermodynamic calculations also indicate that if conditions of the reduction are changed so that a few percent of the PuCl_3 remains in the salt after contact with the reductant, the concentration of rare earth contaminants in the metal product will be lower than with complete reduction of the PuCl_3 . Thus it is indicated that at the expense of plutonium yield, greater decontamination from rare earth impurities may be achieved. In the reduction with lanthanum, incomplete reduction may be achieved by shorter contact times between the lanthanum and the salt or by limiting the amount of lanthanum added to an amount insufficient to reduce all the PuCl_3 present.

In the cerium reductions, the plutonium yield ranges from a minimum of 90% to 93% as the cerium added to the salt is increased from the stoichiometric amount to a large excess, provided the temperature is maintained at about 700° C., as indicated in Examples 10, 13 and 14. A comparison of such examples with Example 12 indicates a higher yield at 700° C. than at 650° C. The composition of the alloy may be predetermined at the higher temperature by assuming a 90% yield and furnishing the indicated amount of cerium for the reduction plus an excess to dilute the alloy as desired. Variations of temperature, size of charge, crucible material, etc., may improve the yield. If larger amounts of salt and reductant were to be used, the yield would probably be improved and used as the basis of the necessary computation.

The plutonium yield in the PuCl_3 reductions by cerium diluted with cobalt are somewhat higher, ranging upward from a minimum of 93%. Higher reaction temperatures seem to make little difference if the crucible and its contents are held at the lower melting temperature (550° C.) for a reasonably long time. The composition of the alloy may be fairly accurately predicted by assuming a yield of 93% and adding the appropriate amount of cerium reductant, plus excess cerium and cobalt for dilution as desired. If the conditions of the reduction are changed in such a way as to increase the plutonium yield, the new yield as determined for the changed conditions must be used in computing the amount of Ce-Co alloy to be used in the reduction.

In both types of cerium reduction, diluted and undiluted, Examples 10-18 demonstrate appreciable decontamination from fission products such as lanthanum. Thermodynamic considerations based on the free energies

of formation of the chlorides lead to the conclusion that the cerium reductions leave behind in the slag certain other contamination chlorides, e.g., those of the alkali metals and the alkaline earths calcium, strontium and barium. This conclusion is verified in the examples above with respect to NaCl, which remains unreduced as an inactive constituent of the salt phase.

What is claimed is:

1. A process for obtaining plutonium alloys and simultaneously separating said plutonium from the rare earths other than cerium and lanthanum, the alkali metals, and the alkali earth metals which may be associated with the source of said plutonium, comprising melting a salt phase containing plutonium trichloride and chlorides having negative free energies of formation not less than that of plutonium trichloride under an inert gas blanket maintained during said process at not more than about atmospheric pressure, contacting said salt phase with a reductant selected from the class consisting of cerium and cerium-cobalt alloys, the composition and amount of said reductant being such as to provide at least the stoichiometric amount of cerium for complete reduction of said plutonium trichloride, heating the reactants as necessary to a temperature of 550° C. to 775° C. the temperature being maintained until the reduction reaction reaches substantial equilibrium, and thereafter allowing said reactants and products to cool to room temperature.

2. The process of claim 1 in which said reductant is cerium and said salt phase consists essentially of plutonium trichloride and sodium chloride in an approximately eutectic composition plus a minor percentage of said other chlorides, the amount of said cerium added being in a range from a minimum of the stoichiometric amount required for the complete reduction of said plutonium trichloride to a maximum of an excess to yield an alloy of plutonium and cerium containing sufficient plutonium for a nuclear reactor fuel.

3. The process of claim 2 in which said cerium range in said product alloy is from about 1.1 to about 27 weight percent and the temperature is from about 650° C. to about 710° C.

4. The process of claim 1 in which said reductant is a cerium-cobalt alloy and said salt phase consists essentially of plutonium trichloride and sodium chloride in an approximately eutectic composition plus a minor percentage of said other chlorides, the composition and amount of said alloy relative to the amount of said salt being such that the alloy resulting from said process contains 10 to 20 atomic percent cobalt, plutonium in the range of from the minimum necessary for a nuclear reactor fuel to a maximum of 88 atomic percent, balance cerium, said salt and said reactant alloy being heated together in melting said salt.

5. The process of claim 4 in which said product alloy ranges from about 5 weight percent cobalt, 30 weight percent plutonium and 65 weight percent cerium to about 4 weight percent cobalt, 30 weight percent cerium and 66 percent plutonium, and the temperature is from about 550° C. to about 775° C.

References Cited in the file of this patent

UNITED STATES PATENTS

2,948,586 Moore _____ Aug. 9, 1960

OTHER REFERENCES

"Extractive and Physical Metallurgy of Plutonium and Its Alloys," edited by Wilkinson. Article by Anselin, pp. 61-73.

